

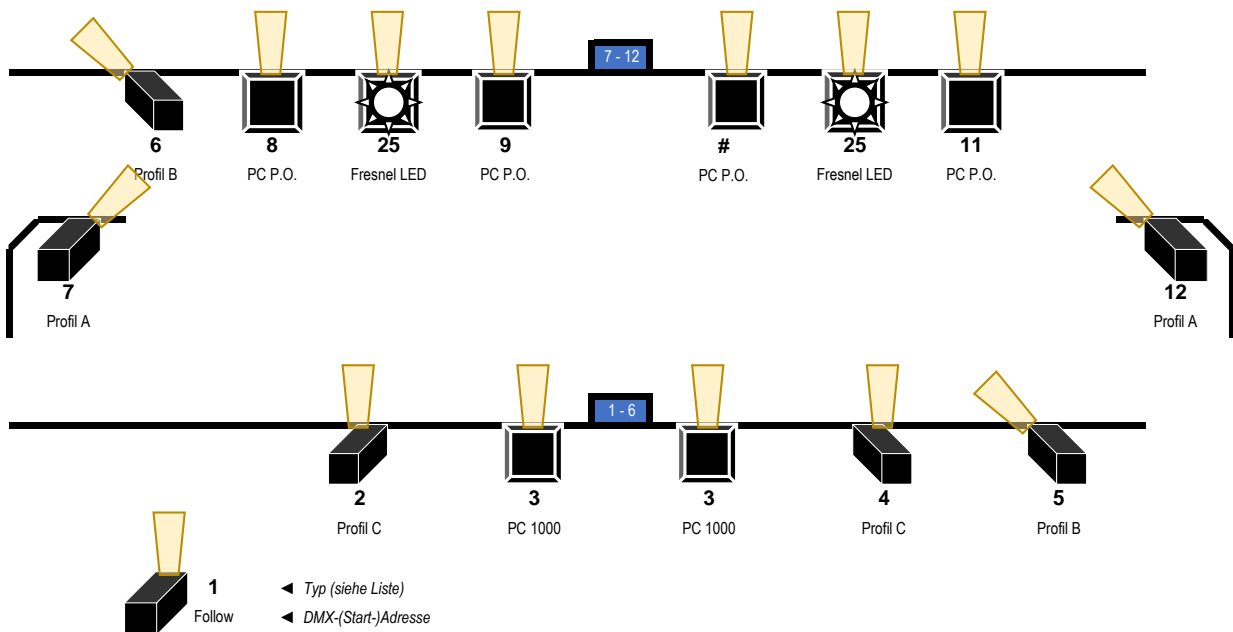

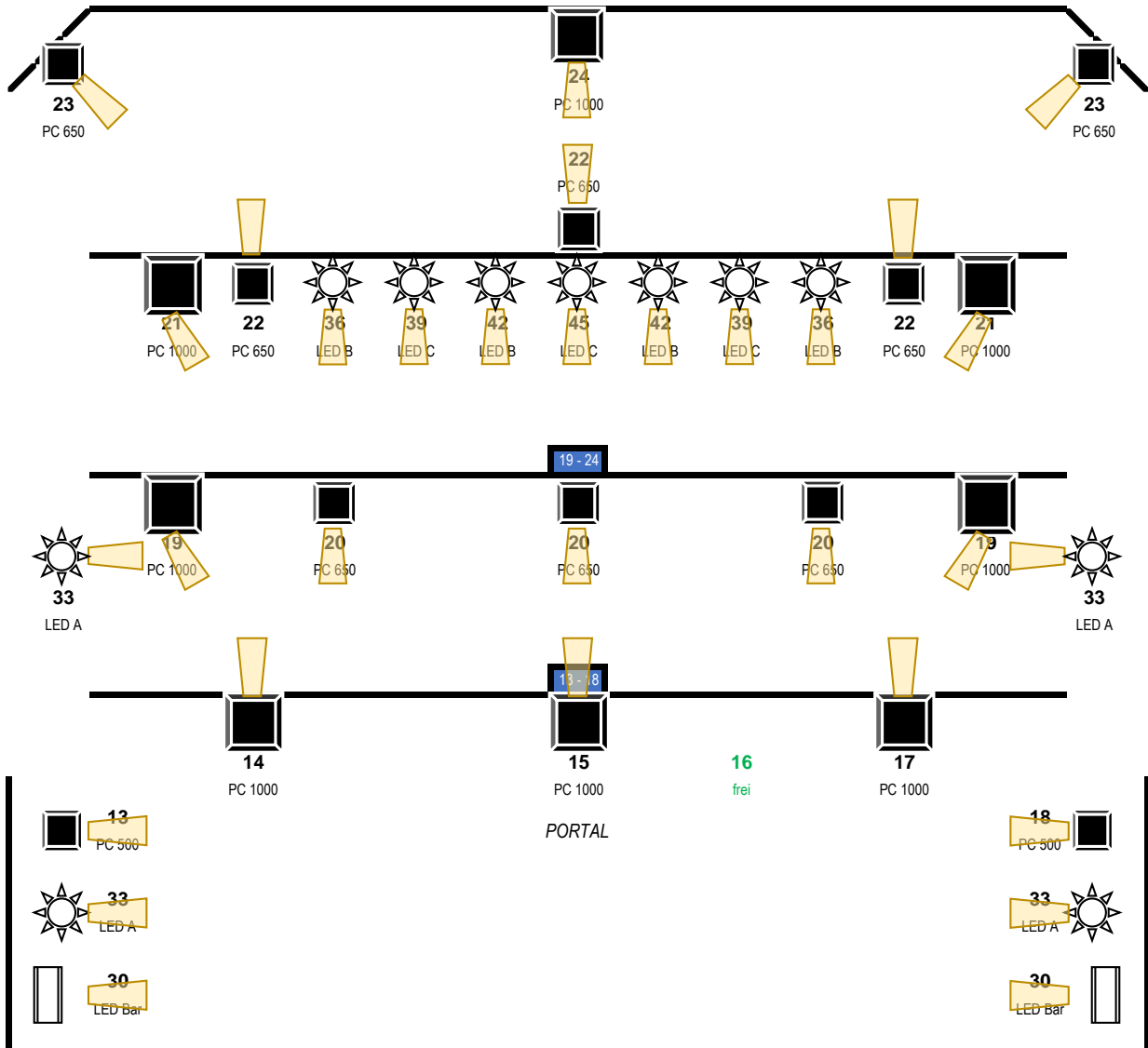

















-  1 Follow
- ◀ Typ (siehe Liste)
- ◀ DMX-(Start-)Adresse



Adresse	Gerät	Ort	Versatz	Funktion	Bemerkungen
1	Verfolger	Technikplatz	-	Dimmer	
2	Profiler 1kW	Raum	1	Dimmer	
3	Stufenlinse 1 kW (2x)	Raum		Dimmer	
4	Profiler 1kW	Raum		Dimmer	
5	Profiler 1kW	Raum		Dimmer	Vorbühne L
6	Profiler 1kW	Vorbühne		Dimmer	Vorbühne L
7	Profiler 1kW	Vorbühne	2	Dimmer	
8	Stufenlinse 1 kW P.O.	Vorbühne		Dimmer	
9	Stufenlinse 1 kW P.O.	Vorbühne		Dimmer	
10	Stufenlinse 1 kW P.O.	Vorbühne		Dimmer	
11	Stufenlinse 1 kW P.O.	Vorbühne		Dimmer	
12	Profiler 1kW	Vorbühne	3	Dimmer	
13	Stufenlinse 500 W	Gasse		Dimmer	
14	Stufenlinse 1 kW	Portal		Dimmer	
15	Stufenlinse 1 kW	Portal		Dimmer	
16				Dimmer	
17	Stufenlinse 1 kW	Portal	4	Dimmer	
18	Stufenlinse 500 W	Gasse		Dimmer	
19	Stufenlinse 1 kW (2x)	Träger 1		Dimmer	
20	Stufenlinse 650 W (3x)	Träger 1		Dimmer	
21	Stufenlinse 1 kW (2x)	Träger 2		Dimmer	
22	Stufenlinse 650 W (3x)	Träger 2	4	Dimmer	
23	Stufenlinse 650 W (2x)	Träger 3		Dimmer	
24	Stufenlinse 1 kW	Träger 3		Dimmer	
25	LED Fresnel (2x)	Vorbühne		Rot	
26				Blau	
27				Grün	
28				Weiß	
29				Zoom (!!!)	15° .. 60°
30	LED Bar (2x)	Gasse		Rot	
31				Grün	
32				Blau	
33	LED PAR 56 (4x)	Gasse (2x)		Rot	
34				Grün	
35				Blau	
36	LED PAR 64 (2x)	Träger 2		Rot	
37				Grün	
38				Blau	
39	LED PAR 64 (2x)	Träger 2		Rot	
40				Grün	
41				Blau	
42	LED PAR 64 (2x)	Träger 2		Rot	
43				Grün	
44				Blau	
45	LED PAR 64	Träger 2		Rot	
46				Grün	
47				Blau	
48	Nebelmaschine			Menge	

Symbol	Anzahl ges.	davon Lager	Bezeichnung	Typ	Leistung	Fassung	Bemerkungen
	2	2	Stiers / NN, PAR 36	Pinspot	30 W	(Schraub)	
	8	8	Coemar "System"	PC	(?) 500 W	GY9.5	uralt
	4	2	Strand Lighting "Minim" 300/500	PC	300 W 500 W	GY9.5	
	12	2 +2 defekt	Strand Lighting "Quartet" 650	PC	650 W	GY9.5	
	1	(1)	Coemar "Solar" 650/1000 Compact	PC	650 W 1000 W	GX9.5	
	8		Showtec "Stage Beam" 650/1000	PC	650 W 1000 W	GX9.5	
	2		Spotlight "Quadro" 1000	PC	650 W 1000 W	GX9.5	
	4		Filmgear 1000 W Tungsten P.O.	PC "P.O."	1000 W	G22	stangenbedienbar
	2		SquareLED Lumino 200W RGBW	Fresnel LED	200 W	LED	Zoom beachten!
	2		Niethammer "HPS 100"	Profil "(A)"	1000 W	GX9.5	
	2		Spotlight "Combi 12" 1000/1200 (?)	Profil "(B)"	1000 W 1200 W	GX9.5	
	2		Strand Lighting "Cantata 18/32"	Profil "(C)"	1000 W 1200 W	GX9.5	
	1		Niethammer "HVV 209"	Follow	2000 W		
	2	2		Fluter	500 W	R7s 118 mm	
	4		ProTech	PAR 56 LED "(A)"	20 W	LED	DIP-Schalter
	4			PAR 64 LED "(B)"		LED	DIP-Schalter
	3		Eurolight "LED PAR-64" RGB Floor	PAR 64 LED "(C)"		LED	
	1			PAR 64 LED "(D)"		LED	DIP-Schalter
	6		Monacor PARC-100/RGB	PAR 64 LED "(E)"		LED	Floor
	2		Showtec LED LightBar RGB	LED Stripe		LED	Display/Menu

alle LED-Scheinwerfer 3-Kanal (RGB), außer:

LED "D": RGB + Colors + Strobe + Macro

LED "E": RGBW + Zoom